

**Product Datasheet model uvex ultravision 9301 626**

**UVEX ARBEITSSCHUTZ GMBH, Würzburger Str. 181-189,  
D-90766 Fürth**

**1. Product Characteristics**

- classic safety goggle suitable for a wide range of applications
- flexible face seal with additional foam layer naturally moulds to any facial shape
- generous internal volume accommodating prescription spectacles and frame recesses to locate the side arms ensuring a comfortable fit
- indirect ventilation system increases air circulation
- length-adjustable textile headband for a secure fit and individual adaptability
- robust polycarbonate lens with uvex's proven supravision coating technology – permanent anti-fog and scratch-resistant lens
- UV400 – 100% protection against dangerous UV radiation up to 400 nm
- a sustainable benefit: lenses can be replaced when required
- metal-free

## 2. Technical Details Body

### Frame

Material	PVC, foam
Version	indirect ventilation
Colour	transparent grey

### Headband

Material	synthetic
Features	individually adjustable
Colour	anthracite, lime

### Headband Hooks

Material	PC
Colour	anthracite

### Marking

Manufacturer 's ID code	W
Applicable EN norm	166
Field of use	3 (drops and splashes of liquid) 4 (large dust particles)
Impact resistance	B (120 m/s)
Resistance to high speed particles at extremes of temperature	T
Conformity symbol	CE

### 3. Technical Details Lens

Material	PC
Thickness	2.2 mm at PD
Coating	uvex supravision excellence
Colour	clear
UV protection	UV400
Replacement lens	9301255
<b>Marking</b>	
Filter	2C-1.2 (EN 170)
Manufacturer 's ID code	W
Optical class	1
Impact resistance	B (120 m/s)
Resistance to high speed particles at extremes of temperature	T
Scratch resistance	K
Antifog	N
Conformity symbol	CE
Factory symbol	

## 4. Logistical Information

### Product

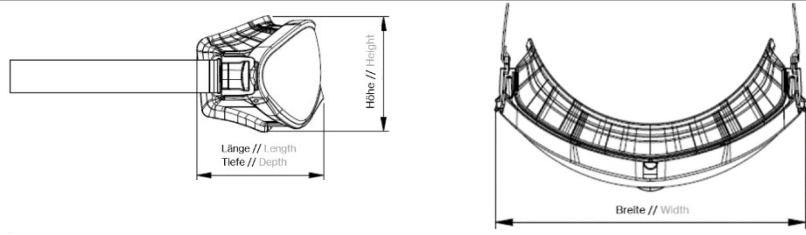
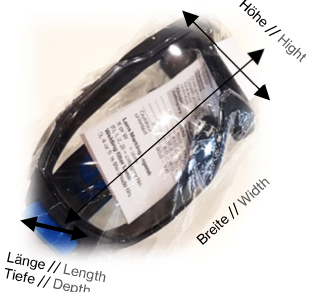
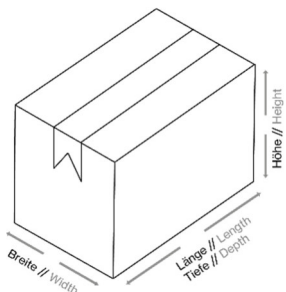
Weight	134g	
Dimensions (L x W x B) in approx. mm		
	95 x 196 x 91 <small>picture only for reference</small>	
	<b>Packing unit 1</b>	<b>Packing unit 2</b>
EAN Code	4031101067971	4031101878911
Quantity in pcs.	1	90
Dimensions (L x W x H) in approx. mm	 <p><small>picture only for reference</small></p>	
	100 x 200 x 91	600 x 400 x 400
Net weight in approx. g	134	12.060
Gross weight in approx. g	152	14.580
Country of Origin	Czech Republic	

## 5. Miscellaneous

Standards	EN 166 + EN 170
PPE Category	Category II